

Since 1971

**HAYMAN**  
QUALITY BUILT SAFES  
Over 40 Years Strong...

**HAYMAN Safe Co.**

brings you the

# Magna Vault EX

**Burglary & Fire Protection** With a touch of Class



## Providing

brute strength and striking beauty, the *Magna Vault EX* is available in 5 sizes. A proprietary 7 step paint process in a great looking Granite color assures years of good looking security.



## Strength

is more than skin deep in a *Magna Vault EX*. The Standard Locking system is an UL Type I Electronic Lock providing multi user access. Tempered Glass and mechanical systems, trigger multiple re-locks that secure the door in the event of a forcible entry attempt. Special "hard plate" protects vital areas of the door and body against drill attacks that other safes easily yield to. This safe far exceeds the UL RSC burglary label it has been awarded.

## Convenience

is not forgotten in a *Magna Vault EX*; from the polished accessory panel located on the back cover all the way to the battery powered LED light system illuminating the interior.

And don't forget about our 1/2" thick tempered glass shelves that adorn the interior of every *Magna Vault EX*. These shelves have been tested to withstand over 200 lbs. of dead weight and provide extraordinary support for your valuables. Laced with a polished stainless steel fascia they look and feel like something belonging in a high end luxury cabinet but perform with a tough as nails attitude as they give increased visibility to the contents of your safe.



When you add it all up, there is no better Burglary & Fire Safe made. For the **Peace of Mind** you deserve, your choice should be a *Magna Vault EX*.

# MagnaVault EX

## Burglary & Fire Protection

With a touch of Class

Available From:

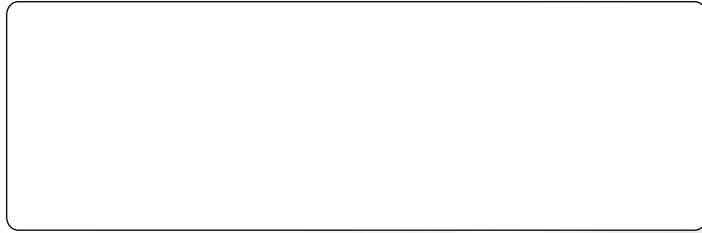

### Burglary Protection

We start with a strong composite material in the body and door that is burglar resistant, and then add:

- Tempered Glass Plate Re-Locker
- Mechanical Re-Lockers
- Extra Heavy Duty Bolt Work
- Large 1 1/8" Chrome Bolts
- Continuous Dead locking hinge bar
- Large ball bearing hinges

We also add angular hardened steel in the body and door at specific locations to deter the type of drilling attack that has been so successful on our competitors safes.



### Fire Protection

In addition to having the right barrier material in the body and door we use an intumescent seal which will swell up to 8 times its thickness to seal out Heat, Smoke & Water.

Our 105 Minute 1200\* fire rating will protect bank note paper from the damages of heat and humidity.

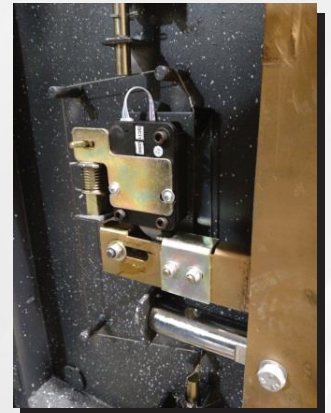
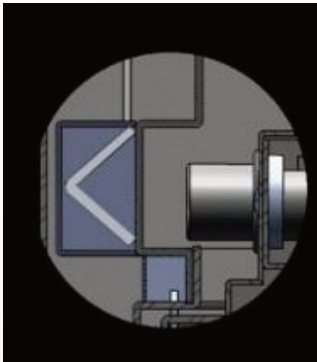

### The EX Difference

- UL listed Electronic Lock
- 7 step proprietary paint finish
- Interior LED Lighting
- Accessory Panel on Back cover
- Tempered Glass Shelves



Four 1" steel plates weighing a total **228 lbs** on a *MagnaVault EX* glass shelf!

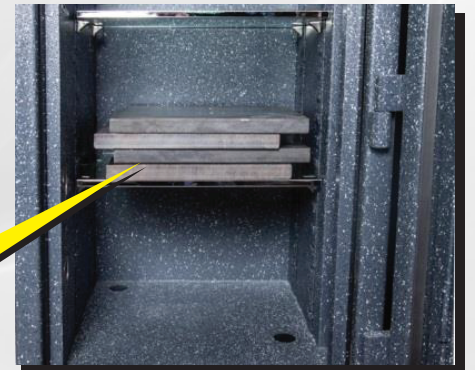

Model	Outside HxWxD*	Inside HxWxD	Weight	Cu.Ft.	Shelves
MV EX-1512	20 1/4 x 17 1/4 x 18 3/4	15 x 12 x 11 7/8	260	1.23	1
MV EX-2116	26 3/8 x 21 3/4 x 21 3/4	21 x 16 1/4 x 14 3/4	410	2.90	1
MV EX-2916	34 x 21 3/4 x 21 3/4	28 3/4 x 16 1/4 x 14 3/4	490	3.98	2
MV EX-3516	40 x 21 3/4 x 21 3/4	34 3/4 x 16 1/4 x 14 3/4	550	4.80	2
MV EX-4020	45 1/4 x 25 1/2 x 27 1/2	40 x 20 x 20	810	9.26	3

\*Add 2 1/4" to the Outside depth for handle clearance